



MAX8884 Evaluation Kit

General Description

The MAX8884 evaluation kit (EV kit) is a fully assembled and tested PCB that demonstrates the highly integrated MAX8884Y step-down DC-DC converter and dual, 300mA, low-dropout (LDO) linear regulator. The step-down output voltage is pin selectable between 1.2V and 1.8V and provides guaranteed output current of 700mA. Dual low-noise LDOs are also integrated in the MAX8884Y/MAX8884Z. The MAX8884 EV kit can also evaluate the MAX8884Z. To evaluate the MAX8884Z, order a free sample along with the EV kit.

Component List

DESIGNATION	QTY	DESCRIPTION
C1, C3, C5, C6	4	2.2 μ F \pm 10%, 10V X5R ceramic capacitors (0603) Murata GRM188R61C225K or Taiyo Yuden LMK107BJ225K
C2	1	4.7 μ F \pm 10%, 16V X5R ceramic capacitor (0805) Murata GRM21BR61C475K or Taiyo Yuden EMK212BJ475K
C4	1	0.033 μ F \pm 10%, 16V X5R ceramic capacitor (0402) Murata GRM155R71C333K
JU1–JU4	4	3-pin headers Sullins PTC36SAAN Digi-Key S1012-36-ND
L1	1	2.2 μ H, 1.3A, 80m Ω inductor FDK MIPF2520D2R2 (2.5mm x 2mm x 1mm)
L2	1	1 μ H, 1.4A, 80m Ω inductor Taiyo Yuden CKP2520 1R0M (2.5mm x 2mm x 1mm)
R1	0	Not installed, resistor (PCB short)
U1	1	Step-down DC-DC converter and dual LDO linear regulators (16 CSP) Maxim MAX8884YEREKE+T
—	4	Shunts (see Table 1) Digi-Key S900-ND or equivalent
—	1	PCB: MAX8884 EVALUATION KIT+

Features

- ◆ **Step-Down Converter**
 - Pin-Selectable Output Voltage (1.2V/1.8V)
 - 2MHz (MAX8884Y) or 4MHz (MAX8884Z)
 - Switching Frequency
 - Low Output-Voltage Ripple
 - 700mA Output Drive Capability
 - Simple Logic ON/OFF Control
 - Tiny External Components
- ◆ **Dual Low-Noise LDOs**
 - Pin-Selectable Output Voltage (LDO1)
 - Low 26 μ V_{RMS} (typ) Output Noise
 - High 65dB (typ) PSRR
 - Guaranteed 300mA Output Drive Capability
 - Individual ON/OFF Control
- ◆ **Tiny External Components**
- ◆ **Low 0.1 μ A Shutdown Current**
- ◆ **2.7V to 5.5V Supply Voltage Range**
- ◆ **Thermal Shutdown**
- ◆ **Tiny, 2mm x 2mm x 0.65mm CSP Package (4x4 Grid)**
- ◆ **Fully Assembled and Tested**

Ordering Information

PART	TYPE
MAX8884EVKIT+	EV Kit

+Denotes lead(Pb)-free and RoHS compliant.

Evaluates: MAX8884Y/MAX8884Z



MAX8884 Evaluation Kit

Component Suppliers

SUPPLIER	PHONE	WEBSITE
Digi-Key Corp.	800-344-4539	www.digikey.com
FDK Corp.	408-432-8331	www.fdk.co.jp
Murata Electronics North America, Inc.	770-436-1300	www.murata-northamerica.com
Sullins Electronics Corp.	760-744-0125	www.sullinselectronics.com
Taiyo Yuden	800-348-2496	www.t-yuden.com

Note: Indicate that you are using the MAX8884 when contacting these component suppliers.

Quick Start

Recommended Equipment

- Variable 6V power supply capable of delivering 700mA (referred to as PS1)
- One voltmeter
- Load resistors or electronic loads capable of 700mA

Procedure

The MAX8884 EV kit is a fully assembled and tested surface-mount PCB. Follow the steps below to verify board operation:

- 1) Place the JU1, JU2, and JU3 shunts across pins 1-2 to enable the step-down converter, LDO1, and LDO2 outputs.
- 2) Place the JU4 shunt across pins 1-2 to select 1.8V for the step-down output and 2.8V for the LDO1 output.
- 3) Preset PS1 to 3.6V. Turn off the power supply. **Do not turn on the power supply until all connections are completed.**
- 4) Connect the positive lead of the PS1 power supply to the IN1 and IN2 pad. Connect the negative lead of the PS1 power supply to the PGND pad.
- 5) Turn on the power supply.
- 6) Verify that the voltage is approximately 1.8V at the OUT pad.
- 7) Verify that the voltage is approximately 2.8V at the LDO1 pad.
- 8) Verify that the voltage is approximately 2.8V at the LDO2 pad. Turn off the power supply.
- 9) Change the JU4 shunt from pins 1-2 to pins 2-3 to change the step-down and LDO1 output voltage. Turn on the power supply.
- 10) Verify that the voltage is approximately 1.2V at the OUT pad.

- 11) Verify that the voltage is approximately 1.8V at the LDO1 pad.

Detailed Description of Hardware

Step-Down Converter

The step-down converter delivers 700mA with either 1.2V or 1.8V selectable output voltage using VSEL (see Table 1). A hysteretic PWM control scheme ensures high efficiency, fast switching, fast-transient response, low-output voltage ripple, and tiny external components.

LDO1 and LDO2

Dual 300mA low-noise, high-PSRR low-dropout regulators (LDOs) are integrated in the MAX8884Y/MAX8884Z. The LDO1 output voltage is determined by the status of jumper JU4, VSEL (see Table 1). The LDO2 output voltage is preset to 2.8V.

Smaller output capacitors can be used for LDO1 and LDO2 if they are used at less than full-load capability. Refer to the MAX8884Y/MAX8884Z IC data sheet for more information.

Shutdown Mode

The step-down converter, LDO1, and LDO2 are individually enabled or disabled with jumpers JU2, JU3, and JU1 (Table 1).

When the step-down and LDOs are all in shut down, the MAX8884Y/MAX8884Z enter a very low-power state, where the input current drops to 0.1µA (typ).

Table 1. Jumper Function (JU1–JU4)

JUMPER	LABEL	SHUNT POSITION	
		1-2	2-3
JU1	LDO2_EN	Enable LDO2	Disable LDO2
JU2	BUCK_EN	Enable step-down converter	Disable step-down converter
JU3	LDO1_EN	Enable LDO1	Disable LDO1
JU4	VSEL	V _{OUT} = 1.8V, V _{LDO1} = 2.8V	V _{OUT} = 1.2V, V _{LDO1} = 1.8V

MAX8884 Evaluation Kit

Thermal Shutdown

Thermal shutdown limits total power dissipation in the MAX8884Y/MAX8884Z. If the junction temperature exceeds +160°C, thermal-shutdown circuitry turns off the IC, allowing it to cool. The IC turns on and begins soft-start after the junction temperature cools by +20°C. This results in a pulsed output during continuous thermal-overload conditions.

Evaluating the MAX8884Z

To evaluate the MAX8884Z, carefully remove the MAX8884Y (U1) and install the MAX8884Z. The inductor L1 also needs to be replaced by the extra inductor (L2) on the EV kit.

Evaluates: MAX8884Y/MAX8884Z

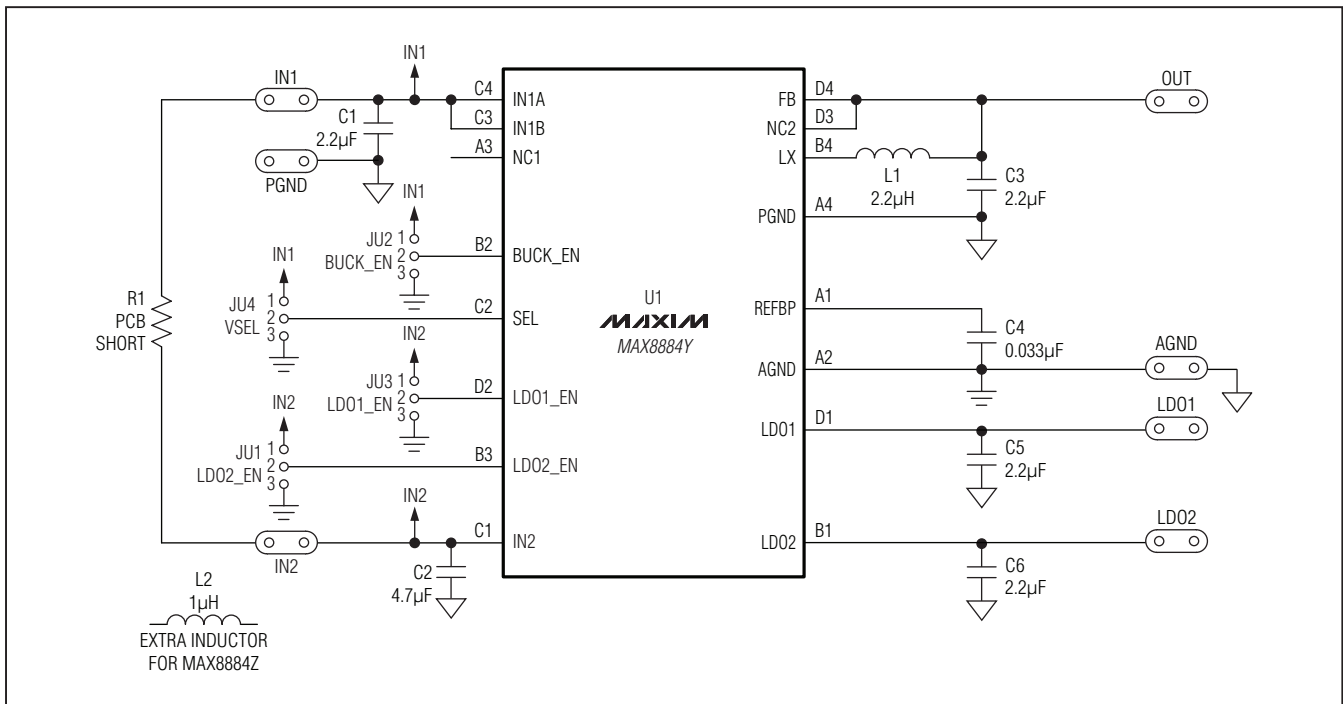

Figure 1. MAX8884 EV Kit Schematic

MAX8884 Evaluation Kit

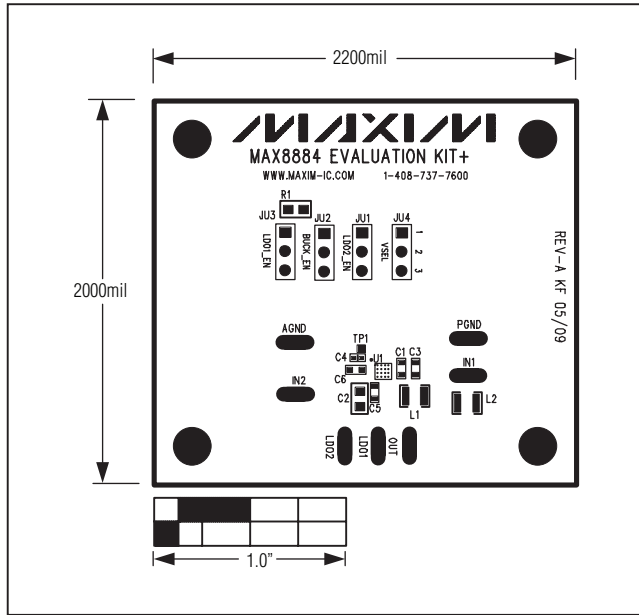

Figure 2. MAX8884 EV Kit Component Placement

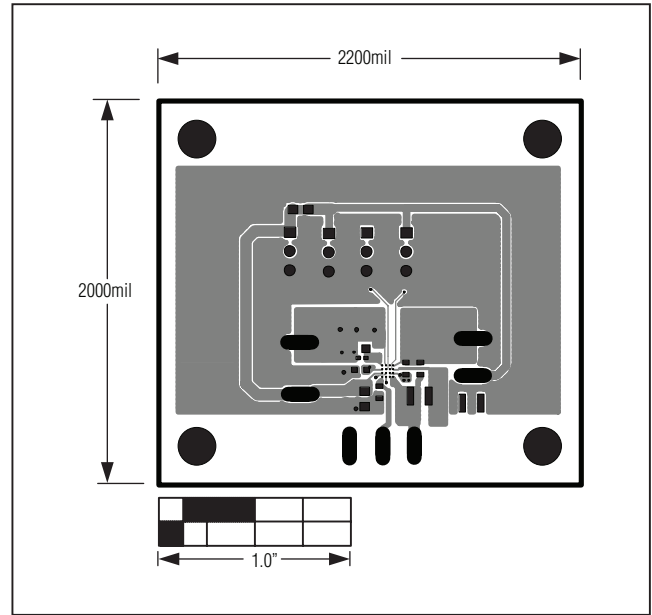

Figure 3. MAX8884 EV Kit PCB Layout—Top Layer

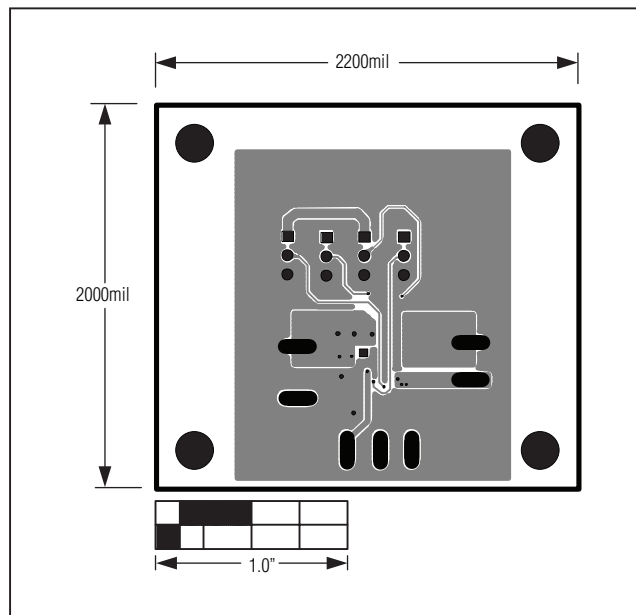

Figure 4. MAX8884 EV Kit PCB Layout—Bottom Layer

Maxim cannot assume responsibility for use of any circuitry other than circuitry entirely embodied in a Maxim product. No circuit patent licenses are implied. Maxim reserves the right to change the circuitry and specifications without notice at any time.

4 _____ **Maxim Integrated Products, 120 San Gabriel Drive, Sunnyvale, CA 94086 408-737-7600**

© 2009 Maxim Integrated Products

Maxim is a registered trademark of Maxim Integrated Products, Inc.